

Diode Protected P-Channel Enhancement Mode MOSFET General Purpose Amplifier/Switch



3N172 / 3N173

FEATURES

- High Input Impedance
- Diode Protected Gate

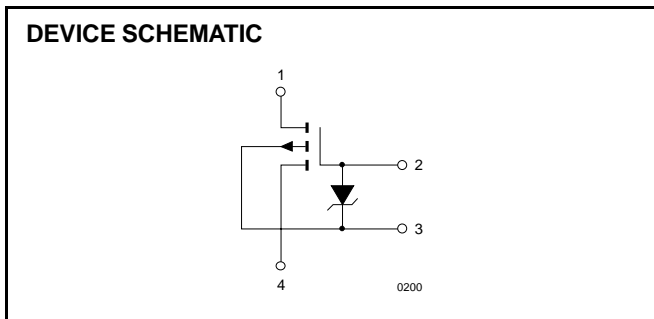
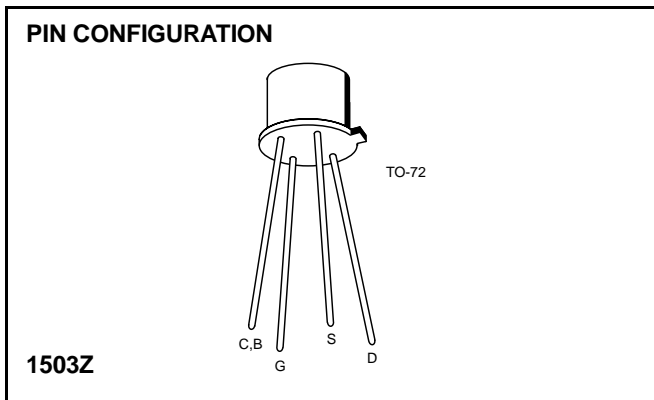

ABSOLUTE MAXIMUM RATINGS

($T_A = 25^\circ\text{C}$ unless otherwise specified)

Drain-Source or Drain-Gate Voltage	
3N172	40V
3N173	30V
Drain Current	50mA
Gate Forward Current	10 μA
Gate Reverse Current	1mA
Storage Temperature	-65 $^\circ\text{C}$ to +200 $^\circ\text{C}$
Operating Temperature	-55 $^\circ\text{C}$ to +150 $^\circ\text{C}$
Lead Temperature (Soldering, 10sec)	+300 $^\circ\text{C}$
Power Dissipation	375mW
Derate above 25 $^\circ\text{C}$	3.0mW/ $^\circ\text{C}$

NOTE: Stresses above those listed under "Absolute Maximum Ratings" may cause permanent damage to the device. These are stress ratings only and functional operation of the device at these or any other conditions above those indicated in the operational sections of the specifications is not implied. Exposure to absolute maximum rating conditions for extended periods may affect device reliability.

ORDERING INFORMATION

Part	Package	Temperature Range
3N172-73	Hermetic TO-72	-55 $^\circ\text{C}$ to +150 $^\circ\text{C}$
X3N172-73	Sorted Chips in Carriers	-55 $^\circ\text{C}$ to +150 $^\circ\text{C}$

ELECTRICAL CHARACTERISTICS ($T_A = 25^\circ\text{C}$ and $V_{BS} = 0$ unless otherwise specified)

SYMBOL	PARAMETER	3N172		3N173		UNITS	TEST CONDITIONS
		MIN	MAX	MIN	MAX		
I_{GSS}	Gate Reverse Current		-200		-500	pA	$V_{GS} = -20V$ $T_A = +125^\circ\text{C}$
			-0.5		-1.0	μA	
BV_{GSS}	Gate Breakdown Voltage	-40	-125	-30	-125	V	$I_D = -10\mu\text{A}$
BV_{DSS}	Drain-Source Breakdown Voltage	-40		-30			$I_D = -10\mu\text{A}$
BV_{SDS}	Source-Drain Breakdown Voltage	-40		-30			$I_S = -10\mu\text{A}, V_{DB} = 0$
$V_{GS(th)}$	Threshold Voltage	-2.0	-5.0	-2.0	-5.0		$V_{DS} = V_{GS}, I_D = -10\mu\text{A}$
		-2.0	-5.0	-2.0	-5.0		$V_{DS} = -15V, I_D = -10\mu\text{A}$
V_{GS}	Gate Source Voltage	-3.0	-6.5	-2.5	-6.5	$V_{DS} = -15V, I_D = -500\mu\text{A}$	
I_{DSS}	Zero Gate Voltage Drain Current		-0.4		-10	nA	$V_{DS} = -15V, V_{GS} = 0$
I_{SDS}	Zero Gate Voltage Source Current		-0.4		-10		$V_{SD} = -15V, V_{DB} = 0, V_{GD} = 0$
$r_{DS(on)}$	Drain Source On Resistance		250		350	ohms	$V_{GS} = -20V, I_D = -100\mu\text{A}$
$I_{D(on)}$	On Drain Current	-5.0	-30	-5.0	-30	mA	$V_{DS} = -15V, V_{GS} = -10V$

SMALL-SIGNAL ELECTRICAL CHARACTERISTICS $T_A = 25^\circ\text{C}$ and Bulk (substrate) Lead Connected to Source

SYMBOL	PARAMETER	3N172		3N173		UNITS	TEST CONDITIONS
		MIN	MAX	MIN	MAX		
$ Y_{fs} $	Magnitude of Small-Signal, Common-Source, Short-Circuit, Forward Transadmittance*	1500	4000	1000	4000	μS	$V_{DS} = -15\text{V}$, $I_D = -10\text{mA}$, $f = 1\text{kHz}$
$ Y_{os} $	Magnitude of Small-Signal, Common-Source, Short-Circuit, Output Admittance*		250		250	μS	$V_{DS} = -15\text{V}$, $I_D = -10\text{mA}$, $f = 1\text{kHz}$
C_{iss}	Small-Signal, Common-Source, Short-Circuit, Input Capacitance*		3.5		3.5	pF	$V_{DS} = -15\text{V}$, $I_D = -10\text{mA}$, $f = 1\text{MHz}$
C_{rss}	Small-Signal, Common-Source, Short-Circuit, Reverse Transfer Capacitance*		1.0		1.0	pF	$V_{DS} = -15\text{V}$, $I_D = -10\text{mA}$, $f = 1\text{MHz}$
C_{oss}	Small-Signal, Common-Source, Short-Circuit, Output Capacitance*		3.0		3.0	pF	$V_{DS} = -15\text{V}$, $I_D = -10\text{mA}$, $f = 1\text{MHz}$

NOISE CHARACTERISTICS

SYMBOL	PARAMETER	TYPICAL	UNITS	TEST CONDITIONS
NF	Common-Source Spot Noise Figure	1.0	dB	$V_{DS} = -15\text{V}$, $I_D = -1\text{mA}$, $f = 1\text{kHz}$, $R_G = 1\text{M}\Omega$

SWITCHING CHARACTERISTICS $T_A = 25^\circ\text{C}$ Bulk (substrate) Lead Connected to Source

SYMBOL	PARAMETER	3N172		3N173		UNITS	TEST CONDITIONS
		MIN	MAX	MIN	MAX		
$t_{d(on)}$	Turn-On Delay Time*		12		12	ns	$V_{DD} = -15\text{V}$, $I_{D(on)} = -10\text{mA}$
t_r	Rise Time*		24		24		$R_G = R_L = 1.4\text{k}\Omega$
t_{off}	Turn-Off Delay Time*		50		50		See Test Circuit Below

*Registered JEDEC Data

SWITCHING TIME DETAIL

MEASUREMENTS ON SAMPLING OSCILLOSCOPE WITH

$t_{rise} \leq 0.2\text{ns}$
 $C_{in} \leq 2.0\text{pF}$
 $R_{in} \geq 10\text{M}\Omega$

INPUT PULSE

$t_{rise} \leq 2\text{ns}$
 PULSE WIDTH $\geq 200\text{ns}$

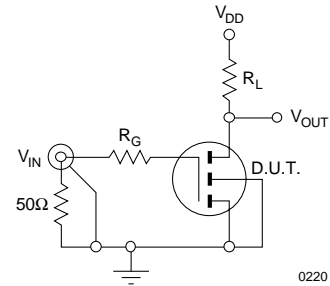

0220

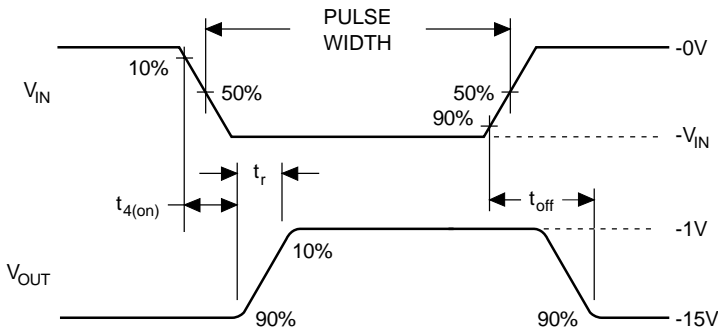

0210

SWITCHING TIMES vs. ON-STATE DRAIN CURRENT

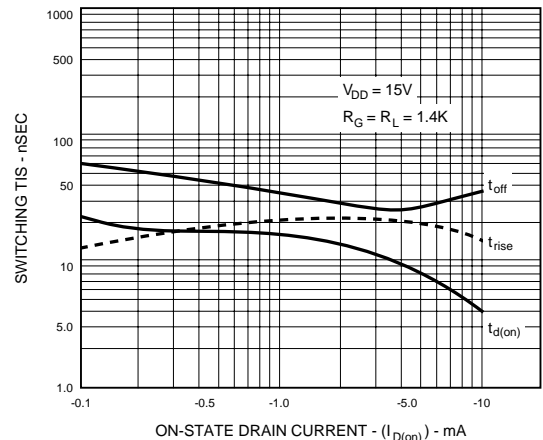

0230

This datasheet has been download from:

www.datasheetcatalog.com

Datasheets for electronics components.